

© KOLEKTOR d.d. in njene povezane družbe. Vse pravice pridržane. Brez dovoljenja je prepovedano kakršnokoli reproduciranje, distribucija, predelava ali druga uporaba.
 © KOLEKTOR d.d. and its affiliated companies. All rights reserved. Any reproduction, distribution, processing or other use is prohibited without permission.

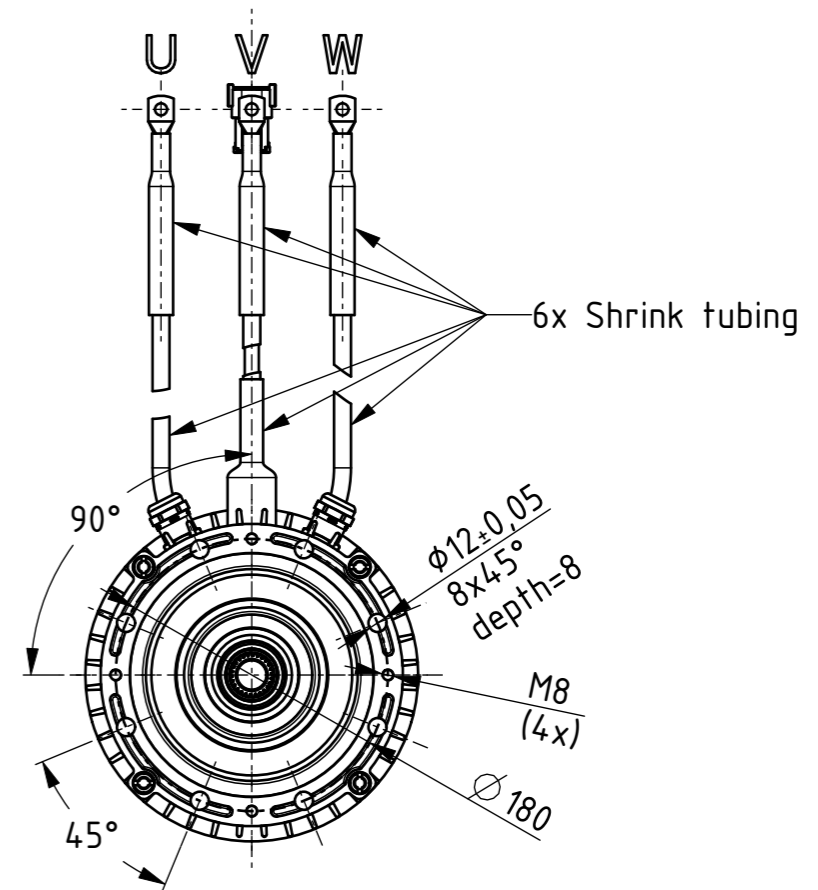
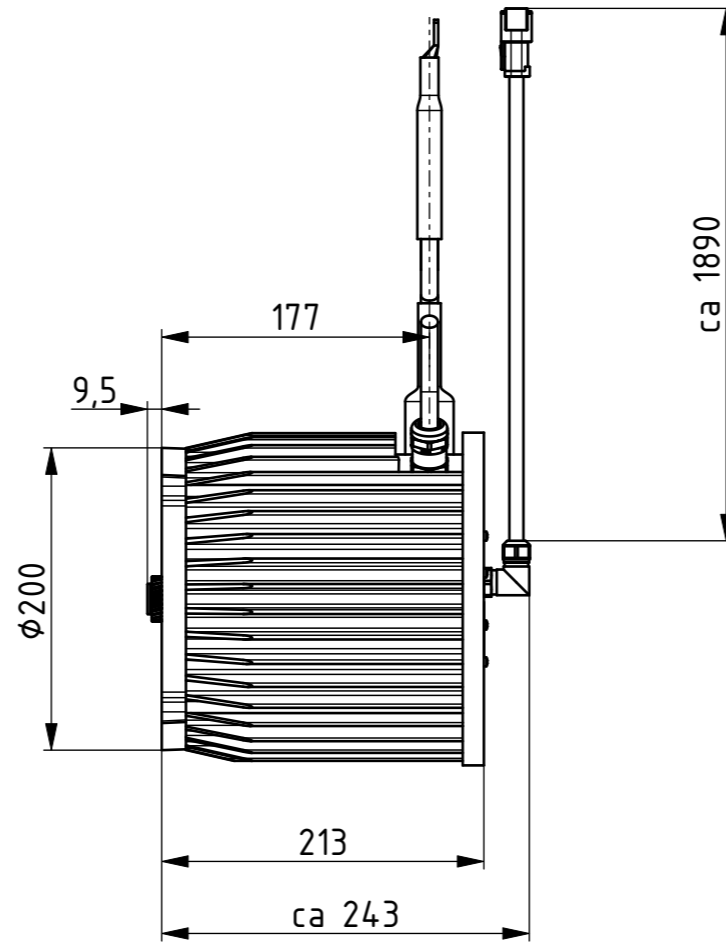
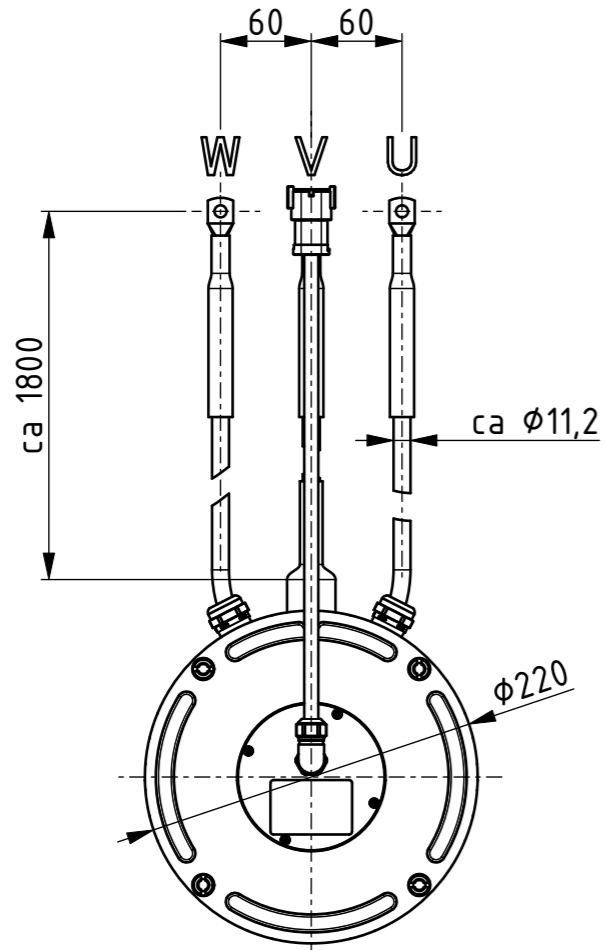

Signal	CONNECTOR DTM04-08PA-E003TE CONNECTIVIT
R1 (Excitation +)	1
R2 (Excitation -)	2
S1 (Sine +)	3
S3 (Sine -)	4
S2 (Cosine +)	5
S4 (Cosine -)	6
Thermistor +	7
Thermistor	(shield) 8

Material	Rev	Status	Format	SAP ID	Koda/Code	Masa/Mass(kg)
	A	In Work	A3	900920	13-1637-06	22
Standard ISO 2768-fK	ECN		Merilo Scale	Naziv/Title		
	Datum Date	06.09.2024	List Sheet	PMBL MOTOR BL180/45		
	Izdelal Created	Tratnik A.				
Hrapavost površine/Surface	KOLEKTOR					
	2D	BL180-45_13-1637-06_900920/A.2				
	3D	BL180-45_13-1637-06_900920/A.1				